



AVK SERIES 813 BUTTERFLY VALVES DOUBLE FLANGED INSTALLATION, OPERATION & MAINTENANCE MANUAL

Instruction for use

Thank you for selecting an AVK product. With correct use, the product is guaranteed to deliver a long and reliable service. This manual has been prepared to assist you with the installation, operation and maintenance of the valve to the maximum efficiency. For ease of reference, it has been divided into sections covering all aspects of use, and it is in the users best interests to read it and ensure that it is fully understood.

Health and Safety

It is always recommended that wherever work is being carried out on a valve that the valve is fully depressurised prior to carrying it out, and for the convenience draining of the line may be beneficial.

It is essential that the user of the valve is aware of the weight of the components and/or assemblies that must be handled and manipulated during installation and maintenance. It is the users responsibility to ensure that safe working practices are followed at all times.

Whenever AVK products are installed, operated, or maintained, it is essential that the staff that undertake these operations be adequately trained. The hazards of pressurised liquids and gases can be severe, and it is the responsibility of the users to ensure that trained, competent staff undertake these duties. This manual has been designed to assist, but it can never fully replace quality training in the workplace. AVK technical staff will always be available to answer any questions relating to specific problems that may not be covered by this manual.

AVK products are designed and manufactured to be fit for purpose, and to a high and reliable standard. This provides a safe product with minimum risk to health when used correctly for the purpose for which it was designed. However, this assumes that the equipment is used and maintained in accordance with the manual, and the user is advised to study this manual, and to make it available to all staff that may need to refer to it.

AVK cannot be held responsible for any incidents arising from incorrect installation, operation or maintenance. The responsibility for this must rest wholly with the user.

AVK SERIES 813 BUTTERFLY VALVES DOUBLE FLANGED INSTALLATION, OPERATION & MAINTENANCE MANUAL

1. Introduction

The series 813 double flanged butterfly valve is a seal on body design complying with AS 4795. The loose liner wraps around the flange face requiring no flange gaskets. The valve is bi-directional and a disc protrusion enables the valve to be used with all water service pipes.

Materials:

Castings (body)
Ductile Iron

Coating
Fusion bonded epoxy (FBE)

Disc, stem, washer, pin bolt and circlip
Stainless Steel

Bush
Alum bronze

Liner
EPDM rubber

Refer to datasheet for specific information



**Australian
Standard**
AS4795.2:2011
Lic. SMK20435
SAI Global



AVK SERIES 813 BUTTERFLY VALVES DOUBLE FLANGED INSTALLATION, OPERATION & MAINTENANCE MANUAL

Component list

- | | | | |
|----------|-------------|------------|----------------------|
| 1. Disc | 4. Stem | 7. O-ring | 10. Stem sealing box |
| 2. Liner | 5. Pin bolt | 8. Bushing | |
| 3. Body | 6. Bushing | 9. Circlip | |

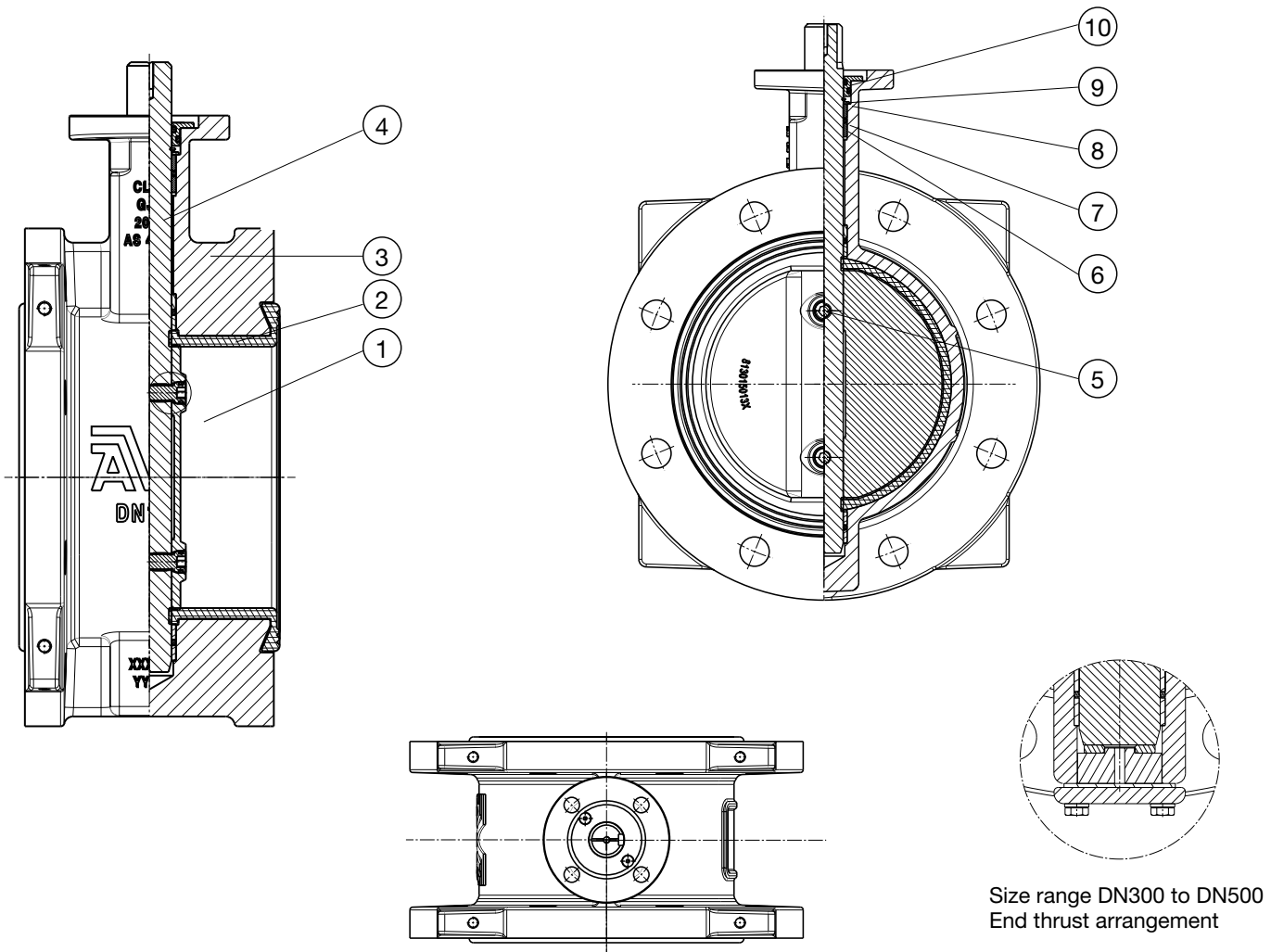

AVK SERIES 813 BUTTERFLY VALVES DOUBLE FLANGED INSTALLATION, OPERATION & MAINTENANCE MANUAL

2. Installation

- When installing the gate valves, ensure that the seats and the flange faces are clean.
- When valves are provided with lifting lugs, plates or eye nuts, these must be used to lift the valve.
- When installed in close proximity of centrifugal pumps orientation of the pump may require vertical orientation.
- Series 813 butterfly valves are designed with an envelope body liner. The liner locks into the flange face providing a raised rubber face. Therefore no flange gasket is required.
- Place valve between pipe flanges, and insert the bolts.
- Tighten bolts loosely.
- Tighten bolts in a diagonal sequence to ensure flanges are pulled parallel.
- Finally tighten bolts to correct torque levels as recommended in WSA **109**.

2.1. Bolts

2.1.1 Bolt size

The following table shows bolt size you should use for which valve dimensions.

DN mm	Bolts	Quantity
80	M16	4
100	M16	4
150	M16	8
200	M16	8
225	M16	8
250	M16	8
300	M20	12
375	M24	12
400	M24	12
500	M24	16

3. Operation

The Series 813 double flanged butterfly valve is designed to AS 4795 and is:

- Bi-directional
- Suitable for submerged and buried service
- End of line service at full rating

DN80, DN100 and DN150 butterfly valves are fitted with a stainless steel lever and notch plate enabling the valve to be locked in the on or off position. DN200, DN250, DN300, DN350, DN400, DN450 and DN500 valves are fitted with a Rotork AB Series ¼ turn gearbox.

Note: DN80, DN100 and DN150 can be supplied with Rotork gearboxes if required.

4. Maintenance

Series 813 butterfly valves are maintenance free. If the body envelope liner is changed during service contact your AVK Distributor or AVK representative for further information.

If the valve is to be stored for a long period prior to installation ensure disc is open approximately 30% and that the valve is operated regularly during storage.

AVK SERIES 813 BUTTERFLY VALVES DOUBLE FLANGED INSTALLATION, OPERATION & MAINTENANCE MANUAL

5 Fitment of Gearbox

1. Hand wheel fitting; slide hand wheel over input shaft and assemble pin / or tighten grub screw on key.
2. The recommended mounting position is end position CLOSED (prior to mounting, bring the gearbox to the mechanical end stop CLOSED by turning the hand wheel clockwise).
3. Thoroughly degrease mounting faces of gearbox and valve.
4. Check if the bolt circle of the flanges mates. Also check drive connections.
5. Prior to locking, dry fit key and gearbox to ensure fit, lightly lube stem and key prior to final fit. Ensure gearbox bore and stem are smooth and free from burrs.
6. In case of usage of stud bolts for fixing the gearbox to the valve, it is recommended to screw them firmly into the gearbox housing before mounting to the valve.
7. Mount gearbox on valve. Ensure that the spigot (if provided) mates uniformly in the recess and that the mounting faces are in complete contact.
8. Fasten gearbox with bolts. Minimum quality 8.8.
9. Fasten bolts crosswise with a torque according to table 1.

Table 1 - Fastening torque in Nm

Bolt	Strength		
	class 8.8	class A2-70 / A4-70	class A2-80 / A4-80
M6	11	8	10
M8	25	18	24
M10	51	36	48
M12	87	61	82
M16	214	100	200
M20	431	150	392
M30	(1489)	564	-
M36	(2594)	-	-

5.1 SETTING THE END STOPS FOR MANUAL OPERATION

1. Close valve, when not in total closed position, and check obturator position.
2. Obturator position;
 - Valve installed: check visually the position mark on valve stem.
 - Valve not installed: measure distance, see picture 1.

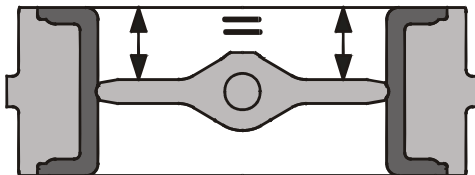

Picture 1

3. Remove protective caps, if present, from the end stops.
4. When the fully closed position cannot be achieved, loosen the end stop by turning them CCW.
5. If the position of the obturator is correct, screw back the end stop until blocked. Secure the end stop with the nut and place protective cap back.
6. Open the valve by turning the hand wheel CCW.
7. When it cannot be achieved to open totally, loosen the end stop. Continue turning the hand wheel until valve is totally open-end.
8. Screw the end stop back until blocked. Secure the end stop with nut and place protective cap.
9. Check if the gearbox indicator is assembled correctly. The indicator shall always be parallel to obturator!
10. Adjustment finished.