



## AVK SERIES 41 CHECK VALVE INSTALLATION, OPERATION & MAINTENANCE MANUAL

### Instruction for use

Thank you for selecting an AVK product. With correct use, the product is guaranteed to deliver a long and reliable service. This manual has been prepared to assist you with the installation, operation and maintenance of the valve to the maximum efficiency. For ease of reference, it has been divided into sections covering all aspects of use, and it is in the users best interests to read it and ensure that it is fully understood.

### Health and Safety

It is always recommended that wherever work is being carried out on a valve that the valve is fully depressurised prior to carrying it out, and for the convenience draining of the line may be beneficial.

It is essential that the user of the valve is aware of the weight of the components and/or assemblies that must be handled and manipulated during installation and maintenance. It is the users responsibility to ensure that safe working practices are followed at all times.

Whenever AVK products are installed, operated, or maintained, it is essential that the staff that undertake these operations be adequately trained. The hazards of pressurised liquids and gases can be severe, and it is the responsibility of the users to ensure that trained, competent staff undertake these duties. This manual has been designed to assist, but it can never fully replace quality training in the workplace. AVK technical staff will always be available to answer any questions relating to specific problems that may not be covered by this manual.

AVK products are designed and manufactured to be fit for purpose, and to a high and reliable standard. This provides a safe product with minimum risk to health when used correctly for the purpose for which it was designed. However, this assumes that the equipment is used and maintained in accordance with the manual, and the user is advised to study this manual, and to make it available to all staff that may need to refer to it.

AVK cannot be held responsible for any incidents arising from incorrect installation, operation or maintenance. The responsibility for this must rest wholly with the user.

# AVK SERIES 41 CHECK VALVE INSTALLATION, OPERATION & MAINTENANCE MANUAL

## Storage

- The valve should not come into contact with any contaminative substances prior to installation
- Valve end protectors (if supplied) should not be removed unless necessary for inspection or installation.
- Protection against weather should be provided. Ideally, valves should be kept indoors with the actual valve temperature always higher than the dew point, particularly for valves fitted with actuators.
- If outdoor storage is unavoidable the valves should then be supported off the ground and protected by a weatherproof cover, from dust-laden damp or saline conditions and at an ambient temperature.
- If long term storage is envisaged, then it may be considered prudent to have a AVK engineer inspect the valve prior to installation.

## Handling

A basic consideration in handling protected valves should be to avoid damaging the coating protection and valves should never be thrown or dropped. Valves whose size requires handling by crane or lift truck should be slung or rigged carefully to avoid damage to exposed valve parts.

Handwheels, bypass, actuators and gearboxes in particular, should not be used as lifting or rigging points for valves.

# AVK SERIES 41 CHECK VALVE INSTALLATION, OPERATION & MAINTENANCE MANUAL

## 1. Introduction

The AVK series 41 Swing Check Valves are designed for horizontal or vertical flow (not suitable for down-flow applications). The design permits full bore flow and enables correct alignment of the resilient seated disc to the body seating surface. The valve comes equipped with a bolted bonnet which can be removed while the valve is in the line.

### Materials:

#### Body and bonnet

Ductile Iron to AS 1831

#### Coating

Electrostatically applied epoxy resin to AS 4158 - Internally and externally

#### Shaft

Stainless Steel

#### Bonnet gasket

EPDM rubber

#### Bushing

Copper alloy AS/NZS 1567

#### Hexagon bolt, washer and pin

Stainless Steel

#### Resilient seated disc

EPDM rubber with a steel insert

#### Hinge

DN 80 - 200: Stainless steel

DN 250 - 300: Ductile Iron to AS 1831

#### Accessory kit:

#### Weight, hinge lever and weight

Ductile Iron to AS 1831

#### Cam

Stainless Steel



# AVK SERIES 41 CHECK VALVE INSTALLATION, OPERATION & MAINTENANCE MANUAL

## Component list

- |                   |                |                   |                      |
|-------------------|----------------|-------------------|----------------------|
| 1. Body           | 8. Nut         | 15. Shaft         | 22. Rubber disc      |
| 2. Bushing closed | 9. Washer      | 16. Bonnet gasket | 23. Hexagon bolt     |
| 3. Bonnet         | 10. Weight     | 17. Tab washer    | 24. Shaft protector  |
| 4. Hexagon bolt   | 11. Grub screw | 18. Nut           | 25. Connector        |
| 5. Washer         | 12. O-ring     | 19. Washer        | 26. Key              |
| 6. Bushing open   | 13. O-ring     | 20. Bushing       | 27. Retaining washer |
| 7. Lever          | 14. O-ring     | 21. Hinge         | 28. Spacer           |

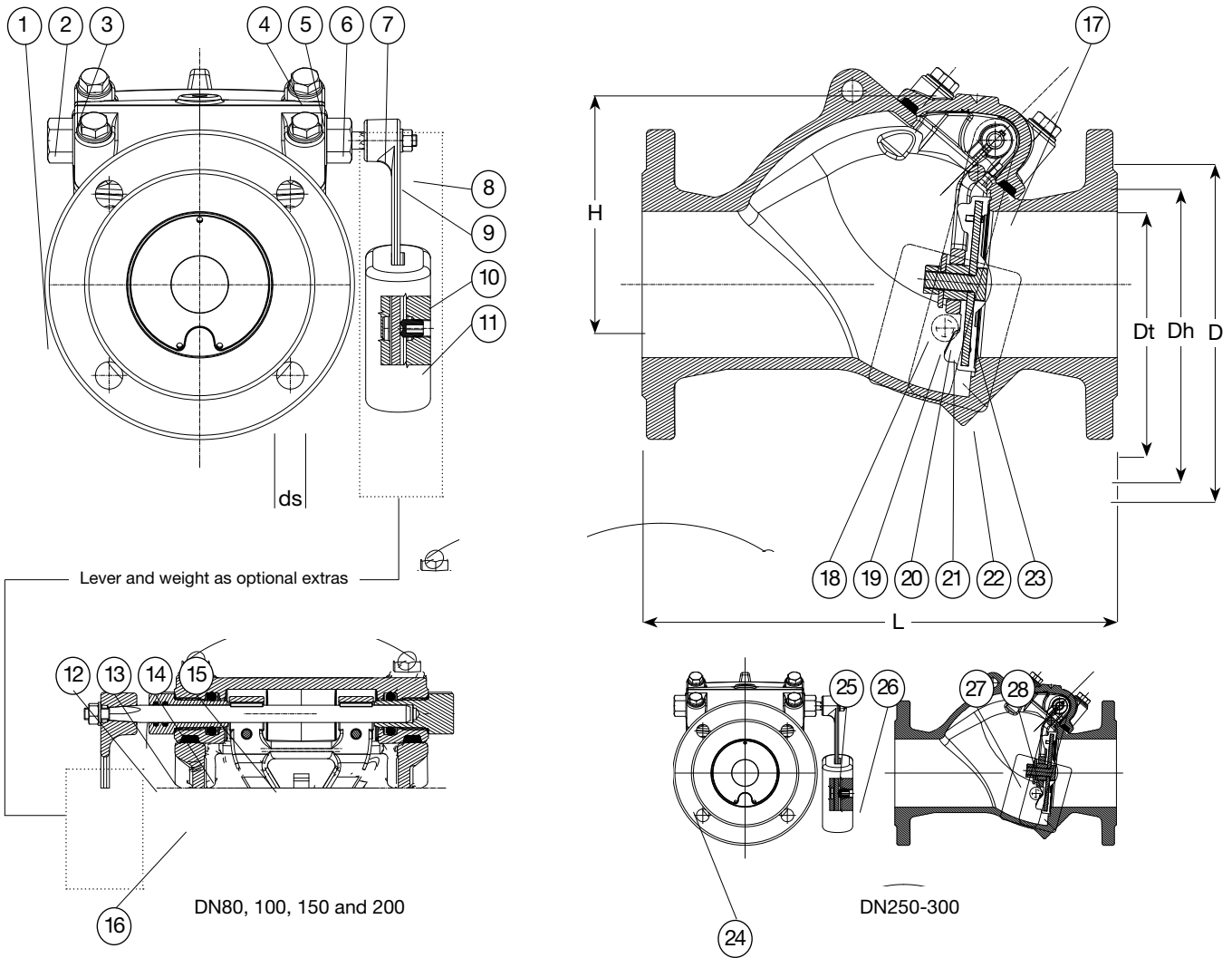

# AVK SERIES 41 CHECK VALVE INSTALLATION, OPERATION & MAINTENANCE MANUAL

## 2. Installation

- a) When installing the check valves, ensure that the seats and the flange faces are clean.
- b) When valves are provided with lifting lugs, plates or eye nuts, these must be used to lift the valve.
- c) To ensure adequate sealing it is important to select the correct type of gasket for the medium concerned, gaskets with the correct flange size must be used.
- d) Place valve between pipe flanges, and insert the bolts.
- e) Tighten bolts loosely.
- f) Tighten bolts in a diagonal sequence to ensure flanges are pulled parallel.
- g) Finally tighten bolts to correct torque levels as recommended in WSA 109.

### 2.1. Bolts

#### 2.1.1 Bolt size

The following table shows bolt size you should use for which valve dimensions.

DN	Table B5		AS 2129 Table E		AS 2129 Table F	
	Bolts	Quantity	Bolts	Quantity	Bolts	Quantity
50	M16	4	M16	4	M16	4
80	M16	4	M16	4	M16	8
100	M16	4	M16	8	M16	8
150	M16	8	M20	8	M20	12
200	M16	8	M20	8	M20	12
225	M16	8	-	-	-	-
250	M16	8	M20	12	M24	12
300	M20	12	M24	12	M24	16
375	M24	12	M24	12	M27	16
400	M24	12	M24	12	M27	20

**AVK SERIES 41 CHECK VALVE  
INSTALLATION, OPERATION & MAINTENANCE MANUAL**

**Horizontal Mounting**

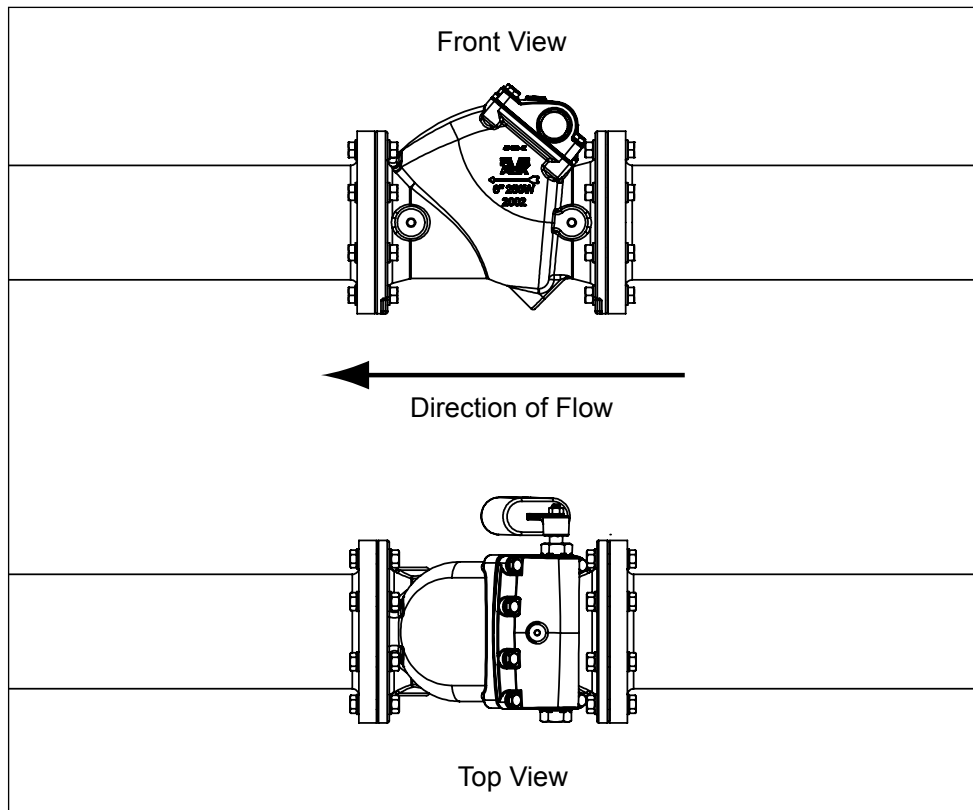

**Vertical Mounting**

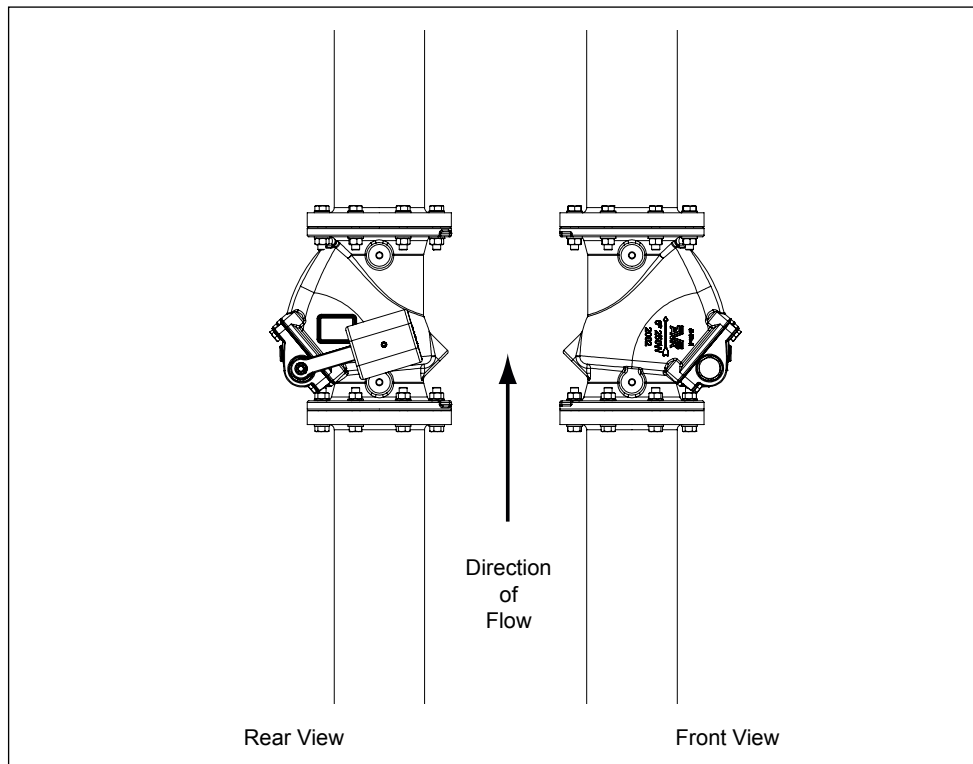

**Lever & weight positions**

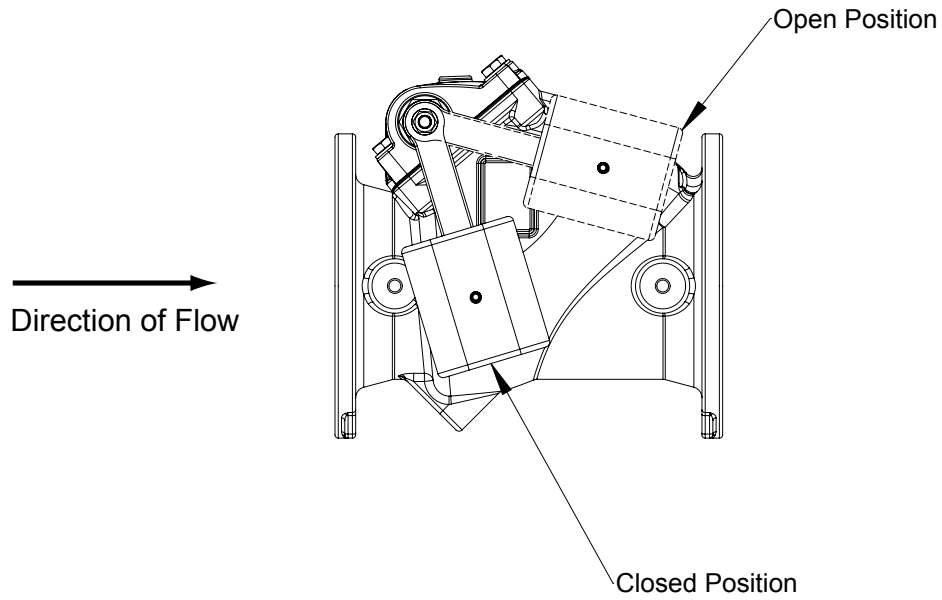

**Horizontal Mounting**

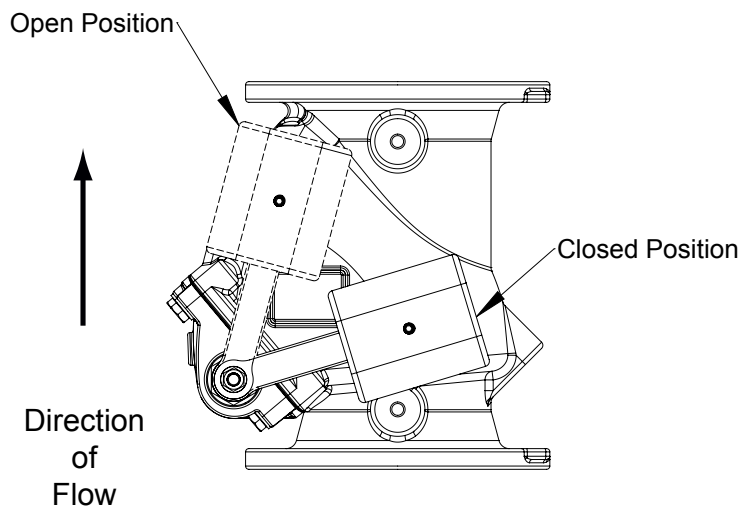

**Vertical Mounting**

# AVK SERIES 41 CHECK VALVE INSTALLATION, OPERATION & MAINTENANCE MANUAL

## 3. Operation

Series 41 Swing Check Valves are suitable for use with wholesome (potable) water and low solids sewage up to 70°C. Minimum liquid temperature must be above freezing.

Insulation is recommended for external temperatures from 0°C to -10°C. They can have a Lever & Weight option, Right Hand as standard.

### Design Constraints

Please consider the following points when selecting your valve:

Consideration should be given at the design stage where valves will be located to give access for operation, adjustment, maintenance and repair.

If a valve is installed less than 5 pipe diameters upstream or downstream of any pump elbow or tee etc., it will experience very high-localised velocities that are far in excess of the average velocity. This high velocity will result in excessive turbulence within the valve and variations in performance may be experienced, therefore installation in this area should be avoided.

Valves must be provided with adequate support. Adjoining pipework must be supported to avoid the imposition of pipeline strains on the body which may impair its performance.

Full flow is achieved with the disc positioned in the bonnet cavity, this occurs when velocity is greater than 1.5m/s. Velocities above 4.5m/s can result in disc flutter reducing pump efficiencies and reducing the life of the valve.

For disc to seal a static pressure differential of a minimum of 70kPa is required.



# AVK SERIES 41 CHECK VALVE INSTALLATION, OPERATION & MAINTENANCE MANUAL

## 4. Maintenance

The valve is designed for use with minimum maintenance and requires no lubrication.

In the event of a spares replacement becoming necessary, the recommended procedure is as follows:

### SAFETY PRECAUTIONS

- Procedures must NOT be carried out whilst the valve is installed in a live main under pressure.
- Ensure main will NOT be recharged before all work on the valve is completed.

#### 4.1 Replacement of Brass Sealing Bushes with 'O' Ring Seals.

##### Component list

1. Body	7. Lever	13. O-ring	19. Washer	25. Connector
2. Bushing closed	8. Nut	14. O-ring	20. Bushing	26. Key
3. Bonnet	9. Washer	15. Shaft	21. Hinge	27. Retaining washer
4. Hexagon bolt	10. Weight	16. Bonnet gasket	22. Rubber disc	28. Spacer
5. Washer	11. Grub screw	17. Tab washer	23. Hexagon bolt	
6. Bushing open	12. O-ring	18. Nut	24. Shaft protector	

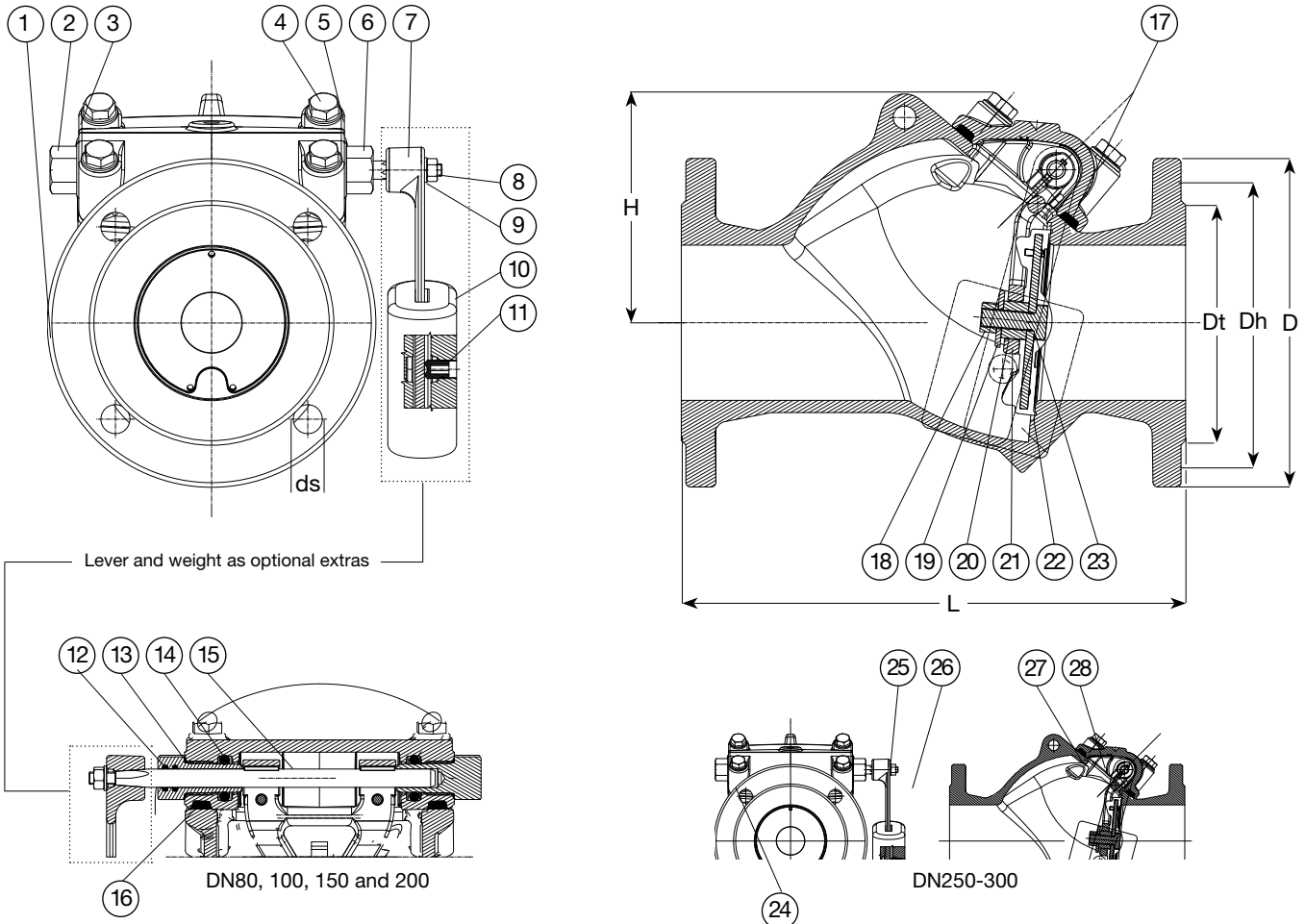

This can only be carried out when there is no pressure in the pipeline.

- If fitted remove nut (8), washer (9) and lever (7) with weight (10).  
NOTE: position of lever relative to body (1) for re-assembly.
- Unscrew either bushing (2) or (6) and replace with new bushing complete with 'O' ring seals.
- Repeat step b) with opposite side bushing.
- Where necessary, refit lever (7), weight (10), washer (9) and nut (8).

# AVK SERIES 41 CHECK VALVE INSTALLATION, OPERATION & MAINTENANCE MANUAL

## 4.2 Replacement of Complete Bonnet Assembly (complete with Shaft, Hinge, Disc and Bushings).

### Component list

1. Body	7. Lever	13. O-ring	19. Washer	25. Connector
2. Bushing closed	8. Nut	14. O-ring	20. Bushing	26. Key
3. Bonnet	9. Washer	15. Shaft	21. Hinge	27. Retaining washer
4. Hexagon bolt	10. Weight	16. Bonnet gasket	22. Rubber disc	28. Spacer
5. Washer	11. Grub screw	17. Tab washer	23. Hexagon bolt	
6. Bushing open	12. O-ring	18. Nut	24. Shaft protector	

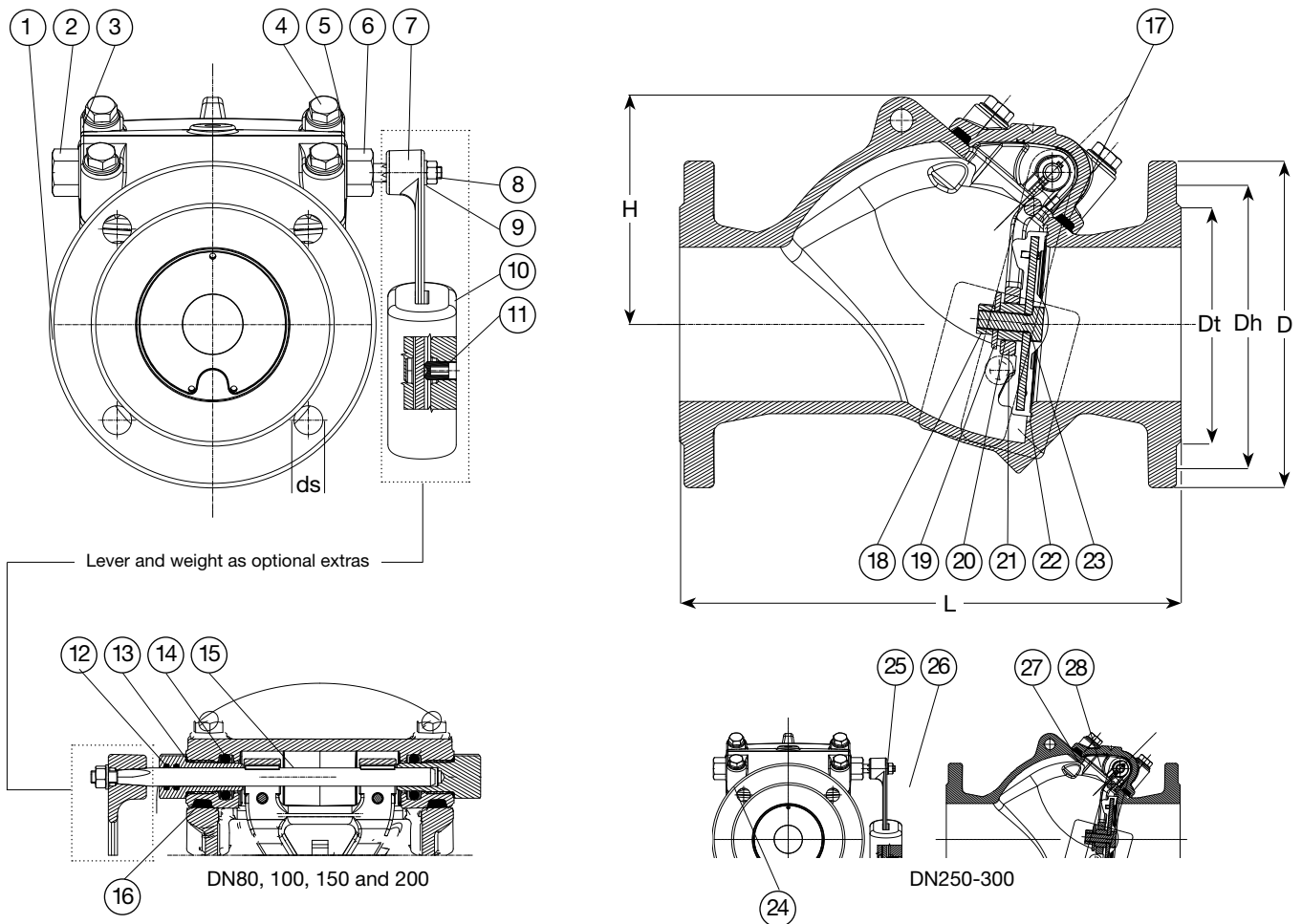

This can only be carried out when there is no pressure in the pipeline.

- a) Remove bonnet (3) by removing hexagon screws (4) and washers (5) and lift completed assembly from body (1). (NOTE: Screws are different lengths.)

### NOTE: If bushings only are to be replaced, follow steps in 4.1.

Check free movement of hinge prior to re-assembling of body.

- a) Ensure that seat area in body is clean.
- b) Fit hexagon screws (4) and washers (note different lengths) (5) through bonnet (1) and fit bonnet gasket (16) over screws (4).  
Fit bonnet (3) into body (1) with disc (23) facing correct way.
- c) Tighten bonnet screws (4) in a diagonal sequence using torque wrench set at 25Nm to 30Nm. Reset the torque Wrench at 40Nm to 50Nm and re-tighten the screws following a circumferential sequence.
- d) Slowly re-charge the main and check integrity of seals.

# AVK SERIES 41 CHECK VALVE INSTALLATION, OPERATION & MAINTENANCE MANUAL

## 4.3 Adding Lever & Counterweight to Series 41 Free End Shaft Valves (DN50 up to DN300).

### Component list

1. Body	7. Lever	13. O-ring	19. Washer	25. Connector
2. Bushing closed	8. Nut	14. O-ring	20. Bushing	26. Key
3. Bonnet	9. Washer	15. Shaft	21. Hinge	27. Retaining washer
4. Hexagon bolt	10. Weight	16. Bonnet gasket	22. Rubber disc	28. Spacer
5. Washer	11. Grub screw	17. Tab washer	23. Hexagon bolt	
6. Bushing open	12. O-ring	18. Nut		

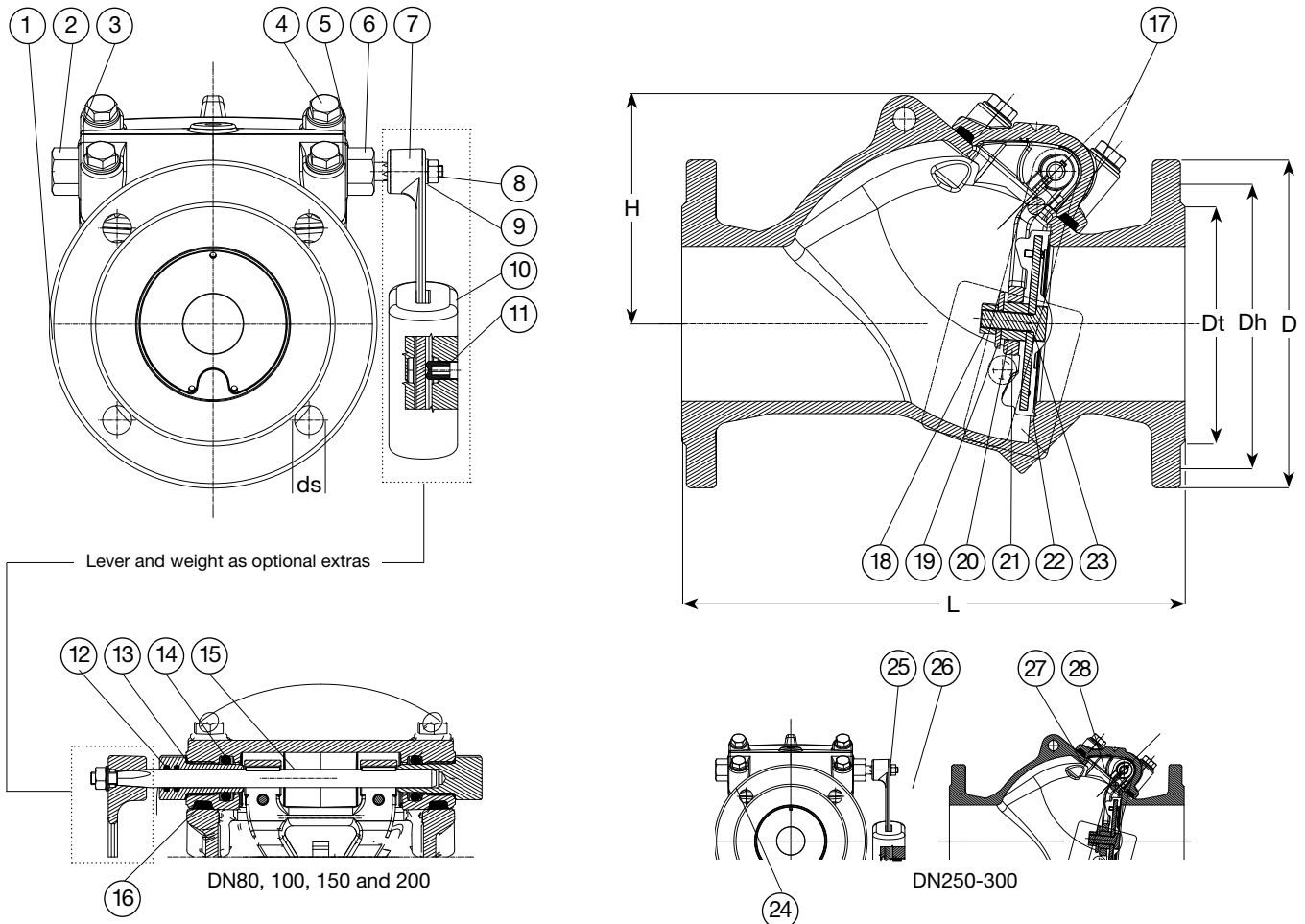

**Safety Precaution :** This can only be carried out, when there is no pressure in the pipeline.

**Fitting of the parts:**

- Remove shaft protector (24) from free end of shaft (15).
- Attached the lever (7) to the shaft (15) and secure with washer (9) and nut (8).  
NOTE: The lever (7) must be aligned on the hexagon flats on the shaft (13) to ensure correct closure of the disc (22) and clearance to a guard, if fitted. The alignment is also important with respect to the installation position of the valve, either vertical or horizontal.
- Mount the counterweight (10) onto the lever (7) and lock its position with the set screw (11). (DN250 & DN300 may have more than one counterweight fitted). The weight can be moved on lever to adjust closing speeds. DO NOT adjust weight while system is in operation.
- Re-connect the flow and slowly fill the valve to check for correct operation.

## AVK SERIES 41 CHECK VALVE INSTALLATION, OPERATION & MAINTENANCE MANUAL

### 4.4 Assembly of Cam Switch

- a) Using M5 Tap clean out bracket bolt holes on side of valve body.  
Ensure that the holes tapped are on the same side as the exposed stem.



- b) Using an Allen key attach the limit switch bracket to the valve body with 2 x M5 screws.

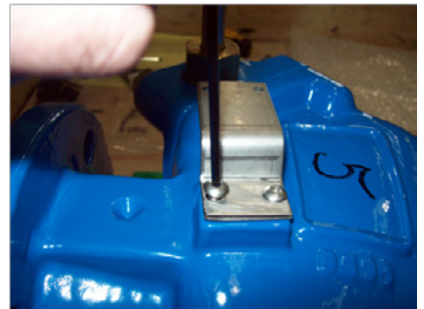

- c) Attach limit switch to bracket with 2 x M4 socket head bolts. Ensure flat washer is behind bolt head and spring washer is behind nut.



- d) With the valve in the fully closed position slide the cam over the valve stem and rotate until switch is engaged. Pull the stem in and out ensuring that it remains in contact with the switch at all times

Once positioned correctly apply a small amount of thread locking compound (Loctite 277) to the grub screw and lock the cam into position.



- e) Check the switch operation ensuring that when the valve is closed the switch remains engaged on the cam. If this does not occur return to step d) and reposition the cam.



# AVK SERIES 41 CHECK VALVE INSTALLATION, OPERATION & MAINTENANCE MANUAL

## 4.5 Installation of Proximity Switch

- a) If not already fitted, fit the standard mechanical switch mounting bracket using two M5 Button Head screws to the side of the valve that the switch will be mounted



- b) Fit the proximity mounting bracket to the mechanical switch bracket using the two M4 socket screws, nuts and washers.  
Note: Ensure the screw, washer and bracket arrangement is assembled correctly in the order of socket screw, flat washer, proximity bracket, mechanical switch bracket, spring washer, nut.



With the grub screw inserted into the proximity cam mount the proximity cam and grub assembly onto the shaft and positioning it centrally to the aperture of the proximity bracket, lightly tighten the grub screw to clamp the cam in a preliminary position.



- d) Insert the proximity switch through the mounting bracket and fit the lock nuts.  
Adjust the proximity switch position in relation to the cam lobe and set the sensing gap to 3mm.  
Tighten lock nuts to secure the proximity switch in position.  
Lock the M5 grub screw in the cam to secure the position and check to ensure the cam does not contact with the proximity switch.



- e) Fit the lever and weight assembly (if required) to the shaft and secure with the locknut and washer. This completes the proximity switch mounting.

